

THIS DRAWING IS UNPUBLISHED. RELEASED FOR PUBLICATION
 © COPYRIGHT BY TYCO ELECTRONICS CORPORATION. ALL RIGHTS RESERVED.

LOC	DIST	REVISIONS					
		P	LTR	DESCRIPTION	DATE	DWN	APVD
EH	00		C	REDWN/REV-EC 0B10-0024-02	19FEB02	LH	MD
			D	REV-EC0-08-024786	07OCT08	LH	JG

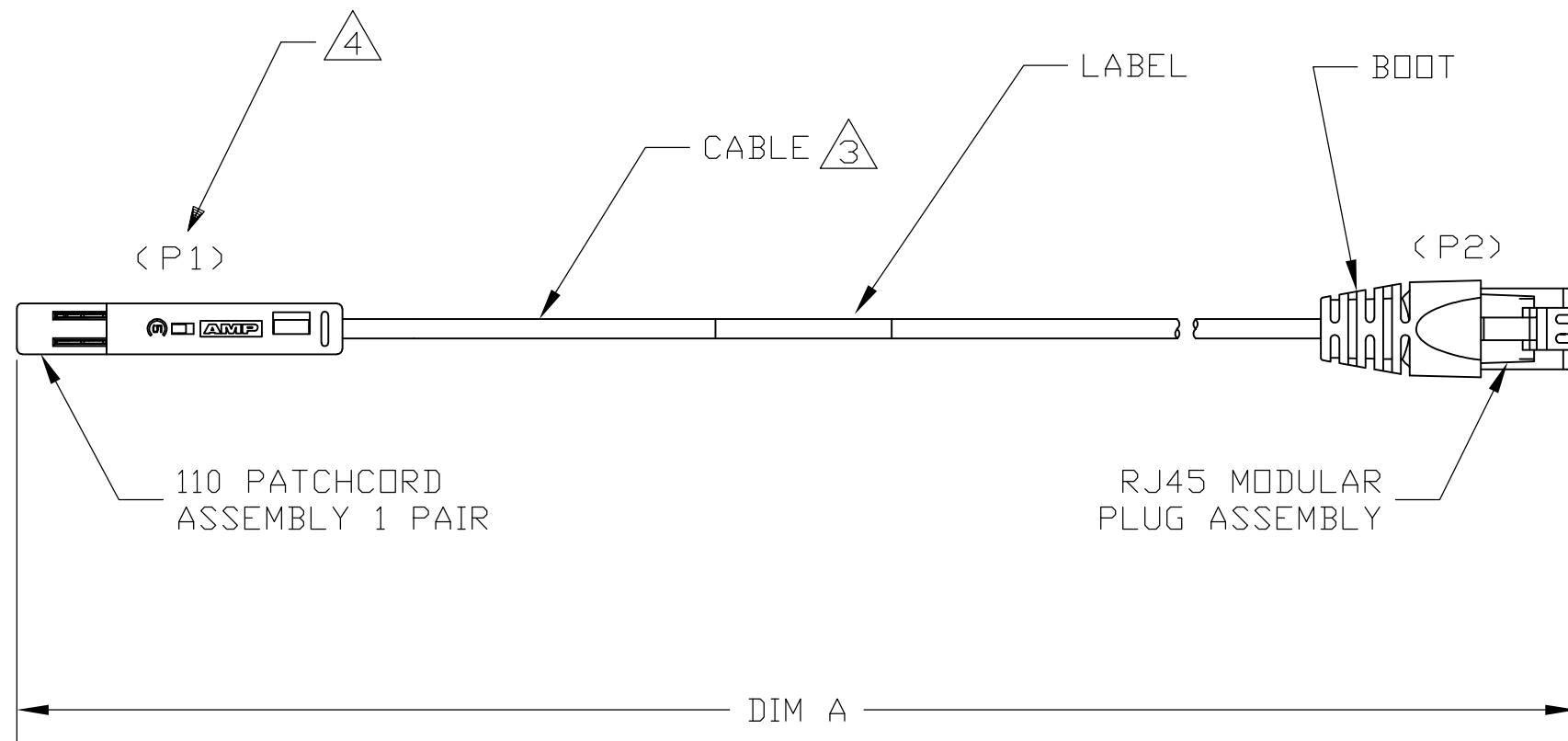

- ONE CABLE PACKAGED IN A CLEAR POLY BAG.
- DIMENSIONS ARE MAXIMUM UNLESS OTHERWISE SPECIFIED.
- CABLE: UNSHIELDED 24 AWG, 2 TWISTED PAIR, 7/32 STRANDED CONDUCTORS, 100 OHMS, CATEGORY 5.
- DESIGNATIONS IN PARENTHESES () ARE FOR REFERENCE ONLY.

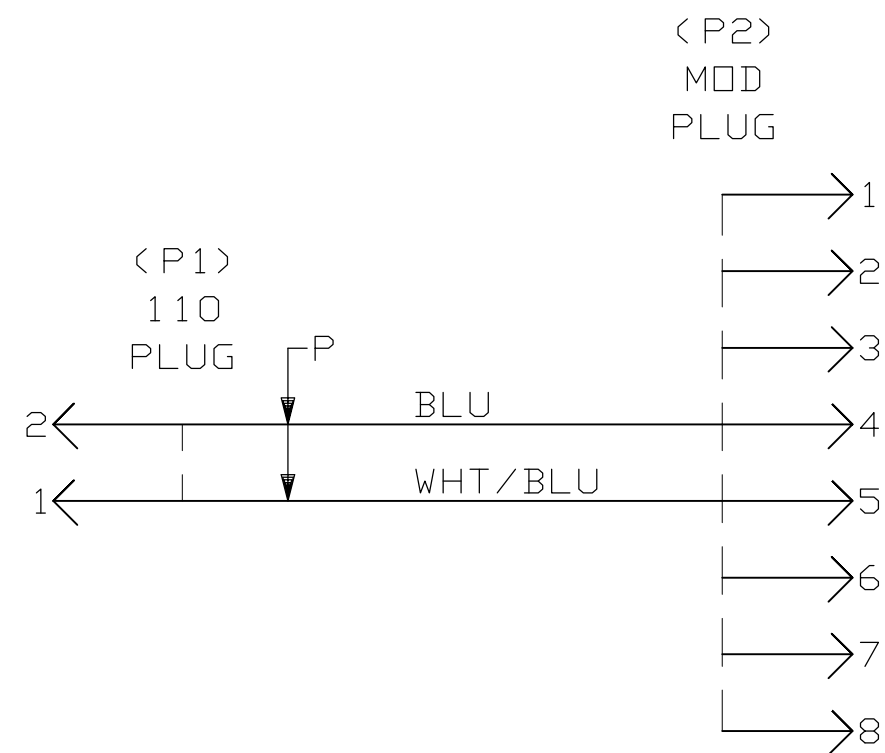

WIRING DIAGRAM

5	16.40	200.80 [5100.3mm]	219831-5
3	9.84	118.00 [3000.0mm]	219831-3
2	5.56	80.72 [2050.3mm]	219831-2
1	3.28	41.36 [1050.5mm]	219831-1
METERS, REF		FEET, REF	DIM A
			PART NO.

THIS DRAWING IS A CONTROLLED DOCUMENT.		DWN L. HALL 21FEB2002	Tyco Electronics Corporation Harrisburg, PA 17105-3608	
DIMENSIONS: MM [INCHES]		CHK M. DELPHIAS 19FEB02	NAME PATCHCORD ASSEMBLY, 1PAIR, 110/RJ45	
TOLERANCES UNLESS OTHERWISE SPECIFIED:		APVD M. DELPHIAS 19FEB02	RESTRICTED TO	
0 PLC ± -	1 PLC ± -	PRODUCT SPEC	SIZE A2	CAGE CODE 00779
2 PLC ± -	3 PLC ± -	APPLICATION SPEC	DRAWING NO C=219831	SCALE NTS
4 PLC ± -	ANGLES ± -	FINISH -	WEIGHT -	SHEET 1 OF 1
MATERIAL -		CUSTOMER DRAWING		
		REV D		